

TYPE AVT VERTICAL BREAK SWITCH

Bulletin No. 42-0807

3-PHASE, GROUP-OPERATED (SUBSTATION AND TRANSMISSION APPLICATIONS)

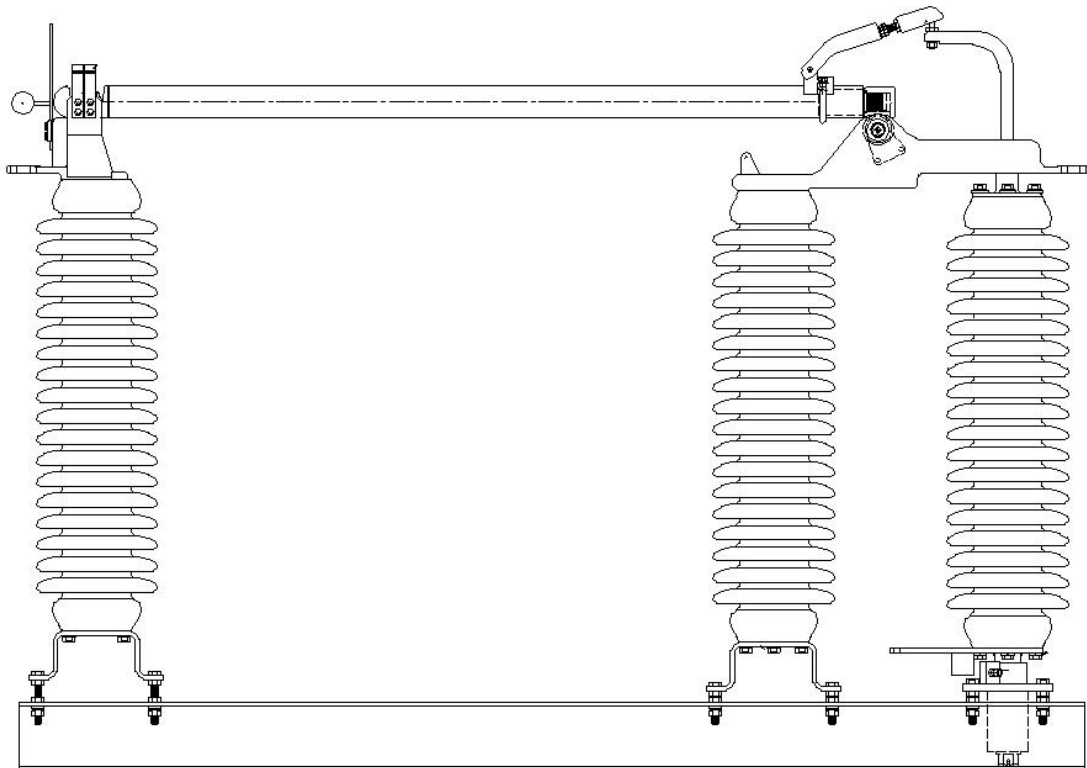

- HORIZONTAL UPRIGHT, VERTICAL OR UNDERHUNG MOUNTING
- 15 kV THROUGH 230 kV
- 1200A THROUGH 3000A
- MANUAL OR MOTOR OPERATED CONTROL MECHANISM

ROYAL SWITCHGEAR MANUFACTURING COMPANY

FEATURES OF THE TYPE AVT SWITCH

The AVT vertical-break switch is an aluminum, three-pole, outdoor, air-break, group-operated, disconnect switch. It has three insulators and is operated by rotation of the outboard insulator on the hinge end. The switch is supplied with a complete operating mechanism including swing handle, vertical operating pipe, outboard bearing, interphase pipe, position indicator and all connecting fittings. Gear and motor operators are available as options. The AVT meets applicable industry standards for electrical and mechanical performance. Applications include disconnecting, isolating or bypassing equipment such as transformers or breakers, and sectionalizing bus and line.

JAW CONTACT

The AVT switch has tin plated copper reverse-loop contacts with silver contact surfaces. This contact design utilizes magnetic forces generated by fault currents to increase contact pressure as the current increases. Insulated stainless steel coil springs maintain contact pressure and are out of the current path. The mating blade contact plate is silver plated copper. The blade rotates in the contact during opening and closing operations. This action cleans contact surfaces and improves ice-breaking capability.

BLADE

The blade is constructed of aluminum tubing with the proven inertia welded hinge assembly welded to the hinge end and an aluminum casting welded to the contact end. An anodized blade is utilized for heat dissipation at 2000A and 3000A.

ALUMINUM CONTACT SURFACES

All aluminum contact surfaces are environmentally protected with an oxide-inhibiting compound.

HINGE CONTACT

The unique hinge design incorporates an aluminum rod inertia welded to a threaded copper rod for high conductivity and proven mechanical strength. The copper rod threads into the hinge casting, which joins the strut casting by threaded tin plated solid copper hinge pins. There are no braids or laminations acting to transfer current. "O" ring seals provide protection from the environment.

GOOSENECK

Solid stainless steel construction assures performance under heavy loads.

BASE

115kV-230kV--Double channel structural steel base is drilled to customer mounting specifications. The base is hot dip galvanized and has jacking bolts in the insulator supports to simplify switch alignment and adjustment. 15kV-69kV--Single channel galvanized steel base is drilled to customer specifications.

COUNTERBALANCE

Steel coil spring in tubular housing assists switch pole operation in any mounting position.

ARCING HORN

Protects switch contacts from arcing damage when low values of switching current are present.

TERMINAL PADS

Drilled to NEMA specifications -- 9/16" holes on 1 3/4" spacing.

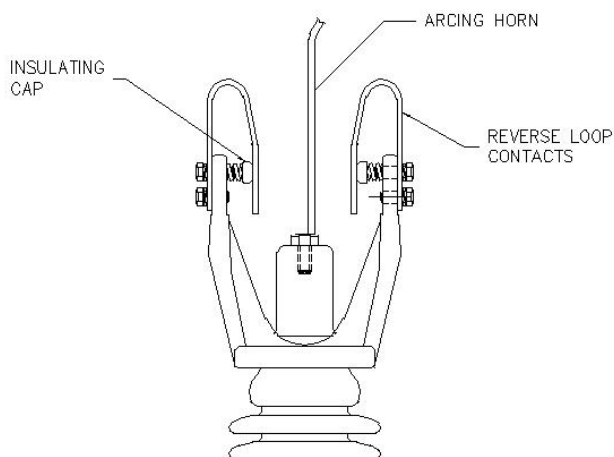

FIG. 1 - CONTACT ASSEMBLY

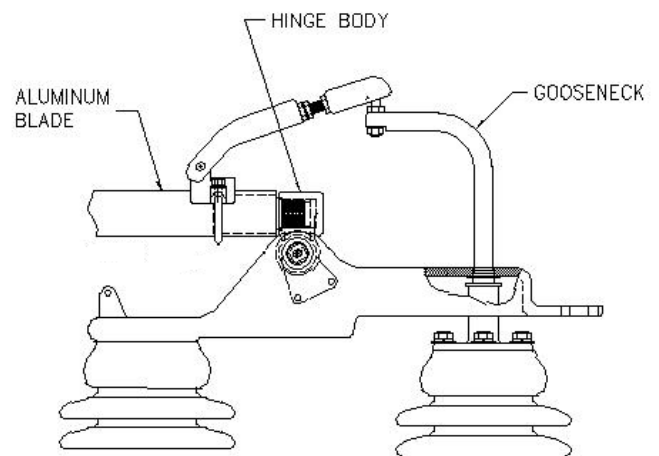

FIG. 2 - HINGE ASSEMBLY

TYPE AVT SWITCH SPECIFICATIONS

kV Nominal (kV Maximum)	Amps Continuous (kAmps Momentary)	Insulator T.R. No.	B.I.L. Rating	Catalog Number	A	B	C	D	E	F	Approx Ship Weight (Lbs.)
15 (15.5)	1200 (61) 2000 (100) 3000 (100)	205	110	AVT1512 AVT1520 AVT1530	15	21	18	52 1/2	47	14 1/2	998 1300 1350
23 (25.8)	1200 (61) 2000 (100) 3000 (100)	208	150	AVT2312 AVT2320 AVT2330	18	21	22	59 1/2	50	14 1/2	1218 1520 1570
34.5 (38)	1200 (61) 2000 (100) 3000 (100)	210	200	AVT3412 AVT3420 AVT3430	24	21	26	69 1/2	56	14 1/2	1348 1650 1700
46 (48.3)	1200 (61) 2000 (100) 3000 (100)	214	250	AVT4612 AVT4620 AVT4630	30	21	30	79 1/2	62	14 1/2	1798 2100 2150
69 (72.5)	1200 (61) 2000 (100) 3000 (100)	216	350	AVT6912 AVT6920 AVT6930	42	21	38	99 1/2	74	14 1/2	2098 2400 2450
115 (121)	1200 (61) 2000 (100) 3000 (100)	286	550	AVT11512 AVT11520 AVT11530	60	21	57 7/8	137 3/8	96	14 1/2	2673 2975 3025
138 (145)	1200 (61) 2000 (100) 3000 (100)	288	650	AVT13812 AVT13820 AVT13830	72	21	66 7/8	158 3/8	108	14 1/2	2898 3200 3250
161 (169)	1200 (61) 2000 (100) 3000 (100)	291	750	AVT16112 AVT16120 AVT16130	84	21	74 7/8	178 3/8	120	14 1/2	3123 3425 3475
230 (242)	1200 (61) 2000 (100) 3000 (100)	304	900	AVT23012 AVT23020 AVT23030	96	21	92 7/8	190 3/8	132	14 1/2	3771 4073 4123

NOTES

1. Dimensions are in inches and are for NEMA standard station post insulators.
2. Counterbalances are standard on all switches 115kV and above.
3. Counterbalances are optional on 69kV switches and below.
4. A gear or motor operator is recommended on 230kV switches.
5. All switches shipped with insulators installed at Royal, except for 230kV. Consult factory if insulators need to be installed on a 230kV switch.

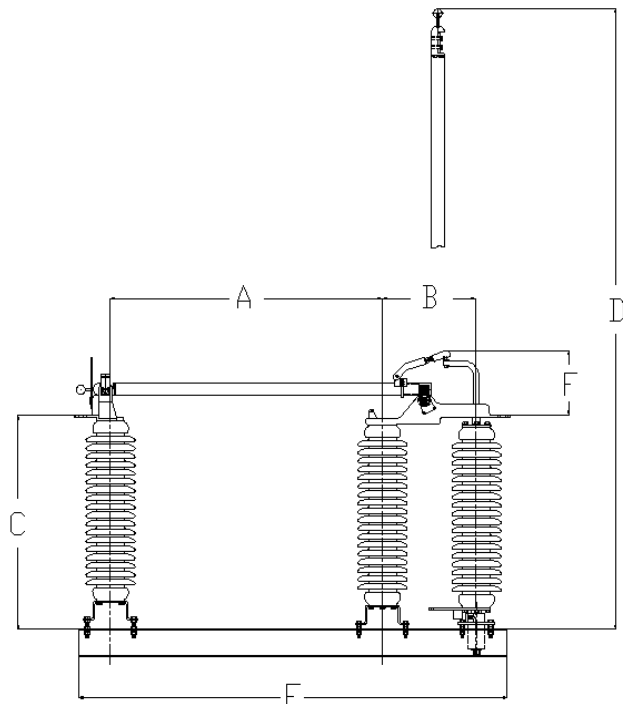

OPERATING CONTROL MECHANISM

The standard control mechanism is the torsional type using galvanized steel pipe. This control includes a toggle arrangement to assure mechanical locking of the switch poles in the open and closed positions. This arrangement gives the AVT switch maximum mechanical capability for ease of operation under normal and icing conditions. The manual swing handle or optional gear operator can be padlocked in either the open or closed position. The manual control can be converted to power operation.

CURRENT INTERRUPTING DEVICES

Arcing Horns

Arcing horns are designed to prevent arcing at the main switch contacts. They have no interrupting rating, however they are commonly used to interrupt small values of current such as transformer magnetizing current or the charging current of a short length of line.

Quick-Break

The quick-break circuit interrupter is capable of interrupting a limited amount of line charging or transformer magnetizing current. It provides high speed contact separation by the means of a spring loaded whip. For successful current interruption the rate of dielectric recovery must exceed the rate of restored voltage across the contacts.

The dielectric characteristics of air can be affected by atmospheric pressure, humidity, wind speed, etc. The rate of recovery voltage depends upon system configuration and operating parameters. For these reasons actual quick-break current interruption performance may vary from the guideline values provided.

Quick-Break Guideline Ratings

Voltage Rating (kV)	Line (Miles)	Current (Amps)	Transformer (MVA)	Loop Load (Amps)
34.5	60	11	35	70
46	50	10	35	70
69	40	10	35	70
115	25	9	75	70
138	20	7	75	70
161	Consult Factory			
230	Consult Factory			

RVI-38 Vacuum Interrupter

The vacuum interrupter will permit currents up to 2000 amperes to be interrupted in loop splitting or parallel switching to 161kV if peak recovery voltage does not exceed 30 kV. It is in the power circuit only for a few seconds during the opening operation and is not in the circuit while the switch is closed or closing. Continuous, momentary and impulse ratings of the switch are not affected.